

Assembly instructions for the **LONG AS YOU LIKE (LAYL) Tile Insert**

The LAYL Channel allows you to customize a floor waste channel to suit the length of any application. Made from 316 SS, it is suitable for indoor or outdoor applications (shower, swimming pool etc). Please use a Bathroom grade Silicon with a mould inhibitor (such as Selleys Wet Area Silicon, coloured grey or clear to match the Channel) to ensure a successful seal is achieved.

BOM

- | | |
|---------------------------|--|
| 1. 2 x Tile Tray End Caps | 6. 2 x End Cover |
| 2. 1 x Tile Tray | 7. 1 x Outlet Kit (1 outlet & 1 strainer) |
| 3. 2 x Tile Tray Leg End | 8. 1 x Burr Stone |
| 4. 7 x Tile Tray Leg Mid | 9. 4 x Pop Rivets |
| 5. 1 x Channel | |

Step 1 - determine channel length

- Measure overall length required for the **LAYL Channel Grate**.
- To determine the correct length of the **Channel** deduct 4mm from the overall length required (the 4mm is made up by the end covers).

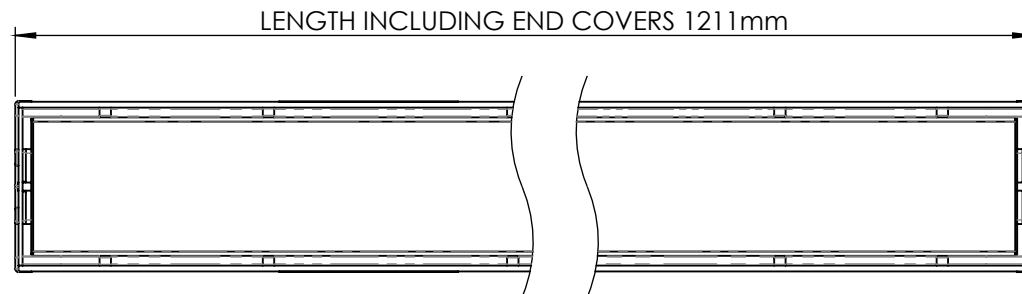
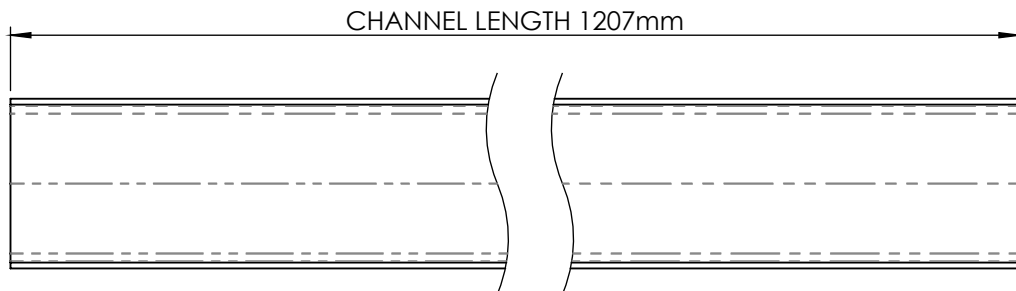
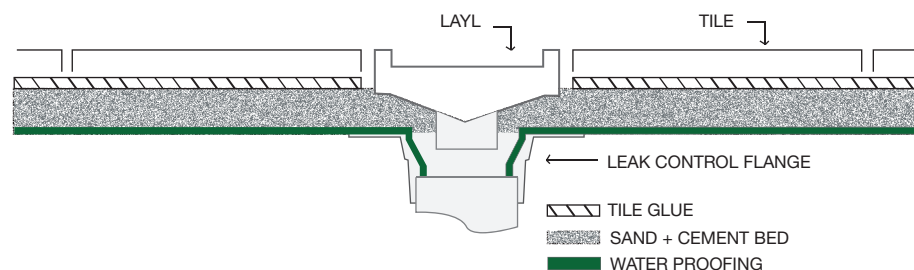
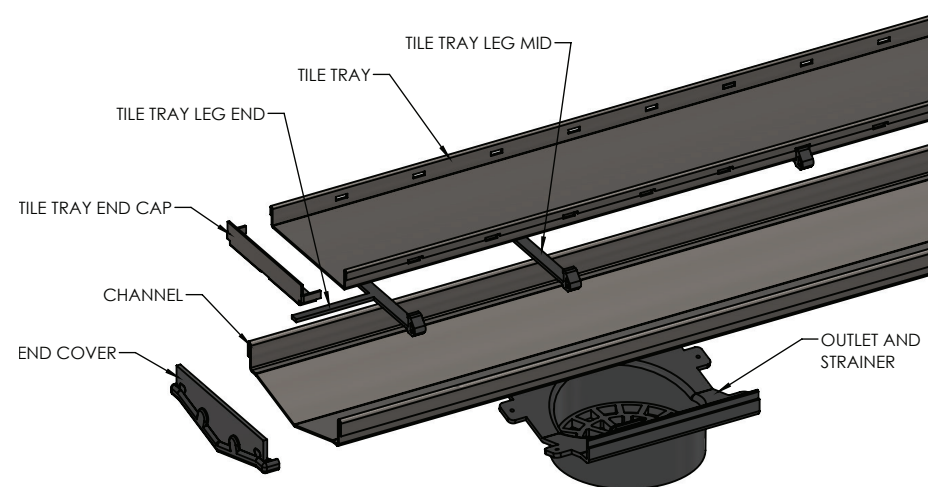

Step 2 - Cut outlet hole

- Mark the center point of the outlet on the inside face of the **Channel**. Ensuring that the hole saw arbor is positioned in the midpoint of the **Channel**.
- With the **Channel** facing up drill a pilot hole with the **Stainless Steel hole Saw** (Artplastics Part No. 34627). Stopping before the hole saw contacts the **Channel**.
- Turn the **Channel** over and using the pilot hole cut the **outlet** hole. Deburr hole using the supplied burr stone. Deburr thoroughly to prevent cuts.

Step 3 - Cut Channel length (If needed)

- Using the **outlet** as a guide mark the length of **Channel** required as per Step 1.
- Cut along guide mark, making sure the cut is straight and is at a 90deg angle. Deburr hole using the supplied burr stone. Deburr thoroughly to prevent cuts.

Step 4 - Assembly

- The **End Covers** are a tight fit to the **Channel**, tap into place. Apply a neat bead of silicon to ensure a successful seal is achieved. Secure **Outlet** to **Channel** with Rivets if needed. Apply silicon to joint to seal.

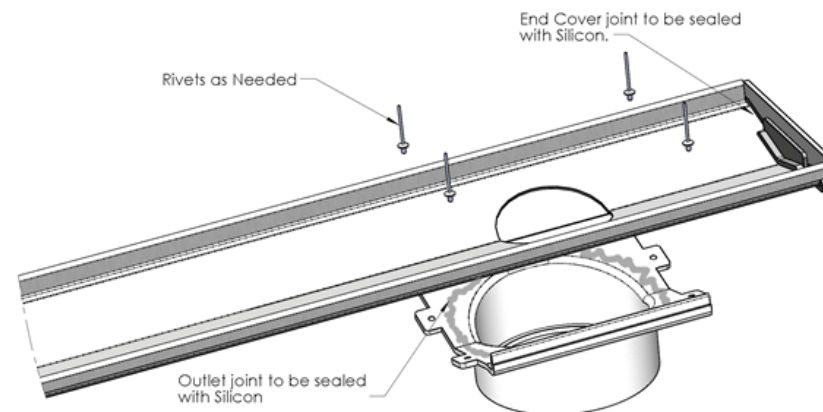

Step 5 - Option A or B Cut Grate length (If needed)

Full Length Tray (OPTION A)

Measure the inside of the channel with end caps on, then take the tile insert tray and cut to length. Evenly space plastic legs to ensure tray sits flat.

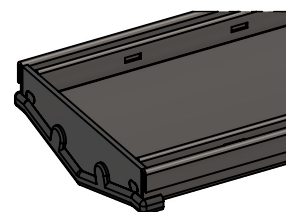

OPTION A
FULL LENGTH TRAY

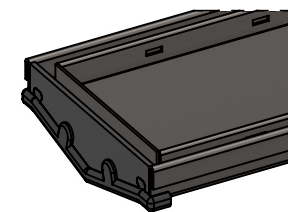

OPTION B
6mm GAP TRAY

6mm Gap Tray (OPTION B)

Measure the inside of the channel with end caps on, then take the tile tray and take 12mm off to allow a 6mm gap around the entire tray. Silicone on end caps provided. Use the plastic legs with spacer attached at the ends of the tray this will stop the tray moving in the channel.

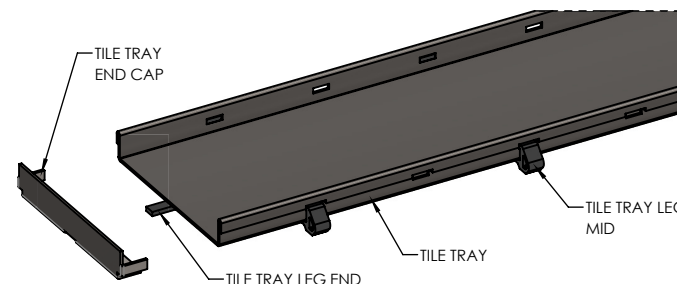

NOTE Ensure that the grate is positioned in the channel when the channel is being tiled up to. See our Instructional Video www.bountybrassware.com.au



Installation should always be carried out by a qualified tradesperson.